



DG-40LWP



deep green
vertical gardens

DG-40LWP panel vertical garden system

Vertical gardens, also known as *living walls* or *green walls*, are a recent innovative development in landscaping with a host of benefits. Vegetation is grown in specially designed systems that are supported vertically, creating exciting new possibilities for landscape, urban and interior design.

Deep Green has been pioneering vertical garden systems for specific application in Western Australia; with specialised lightweight growing media, automated direct reticulation methods and a palette of species specifically selected to be hardy, adaptable and aesthetically pleasing.

Our DG - 40LWP lightweight panel vertical garden system is an adaptable and high-performing vertical garden system ideal for confined spaces or surfaces with a limited weight loading. At just 40mm thick before being filled with media and plants, this highly versatile system can be fitted in the narrowest of spaces, yet with its specialist water retention fibre and planting pockets it is still capable of supporting lush vegetation growth.





Benefits of Vertical Gardens

Temperature - reduced ambient air temperature and load on air conditioning

Surface Area - increased available planting area, such as on fences and walls

Air Quality - absorbs dust, particulates and pollution, naturally filtering the air

Beautification - aesthetically pleasing views and microclimate near garden

Biodiversity - increased biodiversity values and micro habitat creation

The Biophilic Connection

Recent research is proving that exposure to nature is innately healthy for people. A landmark study by Kaplan & Kaplan found that patients recovered faster when able to view greenery from their hospital bed. Further studies are finding evidence for increased employee productivity and wellbeing when workers are kept in touch with nature. With our congested and highly developed urban centres it is becoming harder to introduce new areas of vegetation, but now with vertical gardens previously inert concrete walls can become havens for biodiversity - whilst lowering ambient air temperatures, absorbing pollution and dust particles and becoming aesthetic features in their own right. Further studies have shown how property values can be increased by providing views over vertical gardens versus blank concrete facades.

DG-40LWP panel vertical garden system



DG - 40LWP Panel

Height: 950mm

Width: 1500mm

Depth: 40mm

Weight without media: 10.5kg

Weight with dry media: 15kg

Weight fully saturated: 48kg

Material: Recycled HDPE

Unistrut Supports

Width: 41 or 21mm

Depth: 41 or 21mm

Weight [41mm] : 2.45kg/m

[21mm] : 1.65kg/m

Working load [41mm] : 297kg

[21mm] : 96kg

Material: Hot dipped

Galvanised mild steel

Fixing: Heavy duty wall anchor

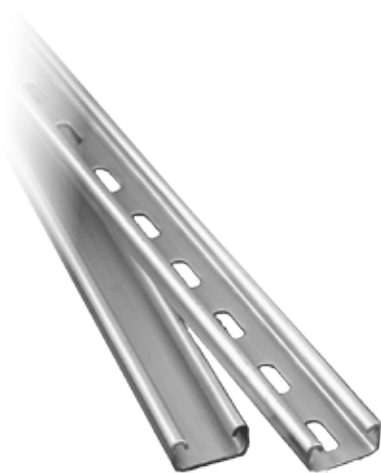

Plants & Media

Media: DG lightweight non -
organic growing media

Grasses: *Lomandra*, *Liriope*
Acorus, *Festuca* etc.

Natives: *Eremophila*, *Hemiandra*,
Olearia, *Scaevola* etc.

Succulents: *Kalanchoe*, *Senecio*,
Sedum, *Echeveria* etc.

Other: *Alternanthera*, *Nandina*,
Asplenium, *Philodendron* etc.



DG-40LWP panel vertical garden system

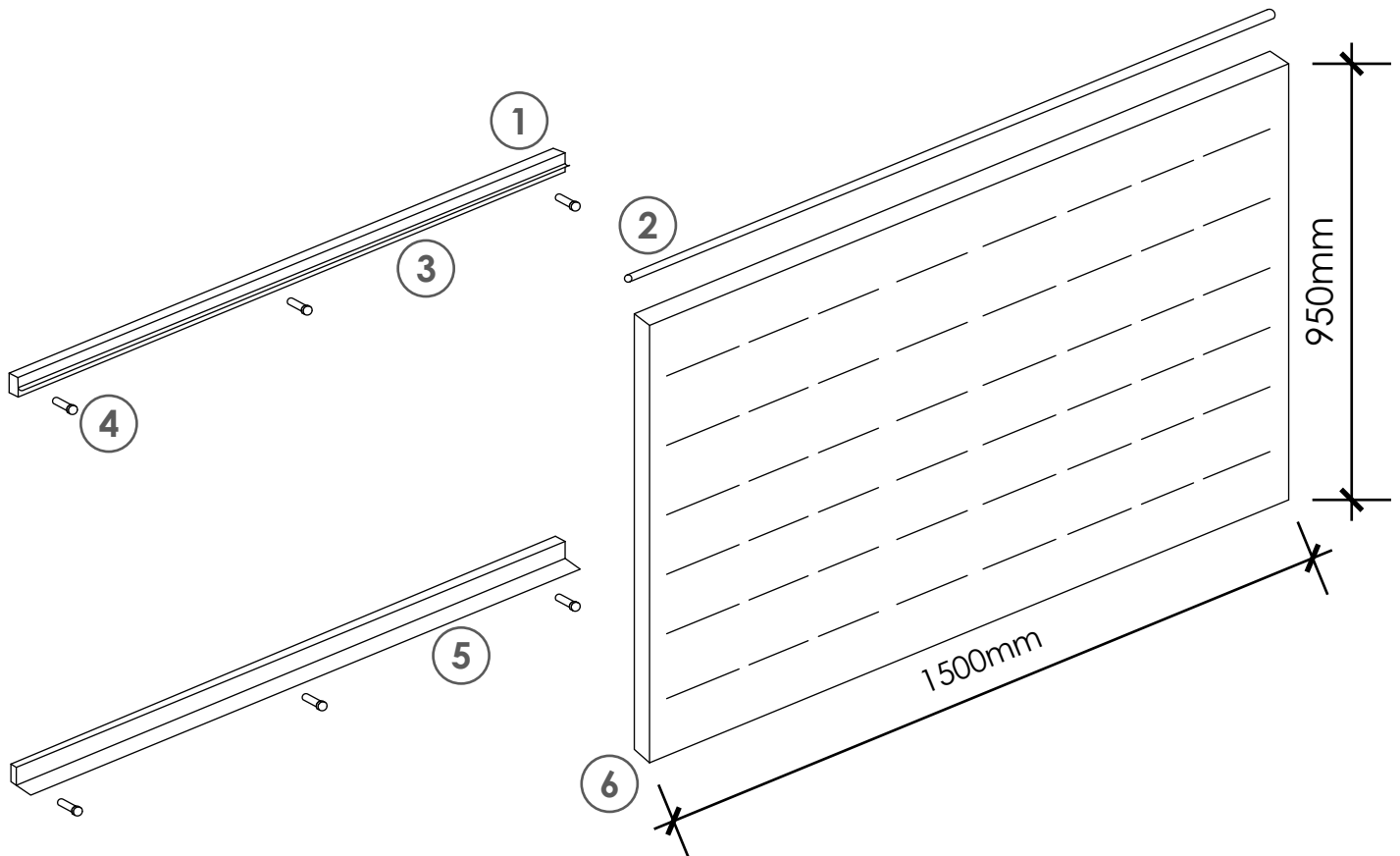

1: Galvanised mild steel Unistrut support system 2: 13mm irrigation line 3: Aluminium J-bar
4: Heavy duty wall anchor 5: Aluminium L-bar 6: DG-40LWP panel



Irrigation & Fertigation Information

Water and nutrient management are critical in ensuring a successful and cost effective vertical greening system. Water management is one of the biggest challenges in vertical greening, especially in Western Australia's harsh climate. The specialist water retention fibre and drip irrigation water supply in our vertical garden systems make them one of the most efficient on the market.

To ensure plants are healthy throughout the lifetime of the system, it is necessary to provide some form of fertilization, as the natural processes of litter accumulation and nutrient breakdown are not present. Our discreet and effective fertigation units are fitted directly into the reticulation system and provide appropriate nutrients directly into the plants root zone, providing optimal establishment and development with minimal intervention.

DG-40LWP design & visualisation

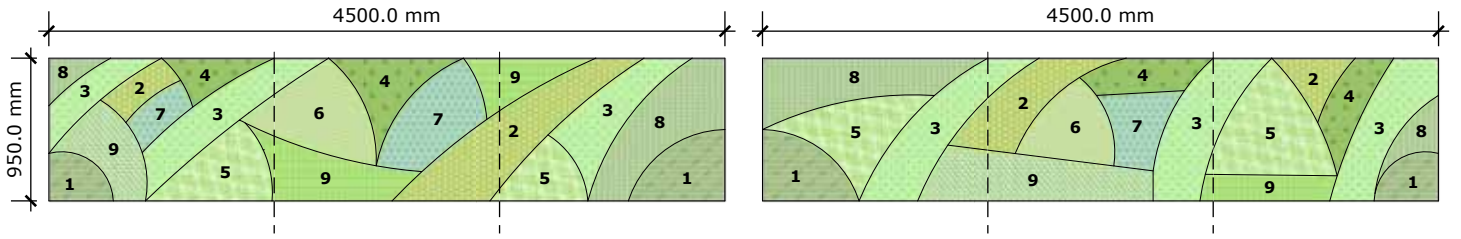

(1) *Tradescantia spathacea* (aka Rhoeo)



(2) *Eremophila glabra* 'Prostrate'



(3) *Liriope* 'Evergreen Giant'



(4) *Alternanthera dentata* 'Ruby'



(5) *Westringia fruticosa*



(6) *Kalanchoe pumila* 'Quicksilver'



(7) *Lomandra confertifolia* 'Little Con'



(8) *Trachelospermum jasminoides*



(9) *Myoporum parvifolium* (broad leaf)







Deep Green Vertical Gardens
www.deepgreenlandscaping.com.au
p: 9242 2299 | f: 9242 2229
23 Colray Av. Osborne Park, 6017